



Eve Teasing Avoidance Gadget Along with Healthcare

Annu Kumari,

Shikha Tripathi,

Sandepti Singh

Electronics and Communication Engineering, SRM University

NCR Campus Modinagar India

Abstract —

The objective of this paper is to design a gadget that can act as a rescue device and can prevent innocent people from harassment. Our endeavor behind this project is to design and fabricate a gadget which is so compact in itself that provide advantage of camouflage. The gadget also contains healthcare system for patients and those who needed critical care. In this paper we provide key points of the gadget and its application in danger time. We also provide information about challenges faced in this field now and in near future.

Introduction

In Indian society, today, are becoming the most vulnerable section as far as their safety and security is concerned. When we turn the pages of a newspaper, we come across many headlines reporting cases of sexual assault, molestation, sexual harassment, rapes, trafficking, ill treatment of women in houses, violence against women in remote areas, murder, robbery etc. This certainly implies that there has been an increasing trend of such crimes in present generation. From the past few days we are experiencing an increment in the cases of eve teasing, pick pocketing etc. In this paper, we are trying to approach towards certain short term and preventive solution. This would mean to have a multipronged strategy with the participation of multi stake holders of society.

As good citizens, we have a fundamental duty to contribute towards bringing an order to ensure a safe and secure for all so that everyone can enjoy their human rights and fundamental rights with sense of pride, freedom and confidence.

Safety is the most wanted power for everyone in today's world. Technology is the best way to achieve it. That's why we decided to develop a gadget that can act as a rescue device and protect at the time of danger. We are providing with such devices which could help one to protect them in the danger time.

Our endeavor behind this project is to design and fabricate a gadget which is so compact in itself that provide advantage of Security. The gadget also contains healthcare system for patients and those who needed critical care. In this paper we provide key points of the gadget and its application in danger time. So far we didn't saw any special security device which can be used by everyone for their protection in critical time. We have made a circuit which when enable gives an electric shock to the attacker. We can give an electric shock a number of times. We have also provided a GSM Modem which sends a SMS to the concerned persons when circuit for electric shock is switched 'on'.

Besides that we even added a healthcare system for the persons who need critical care while travelling. In our project, we had provided a temperature sensor which senses body temperature. Body temperature means measurement of the body's ability to generate and gets rid of heat. It is one of chief indicators of normal functioning and health. The nature of the human body is to keep its temperature within a narrow, safe range in spite of large variations in temperatures outside the body. Normal human body temperature depends upon the place in the body, from which the measurement is made, and the time and level of

activity of the person. The sensor gives the information of body temperature and it can be sent to concerned people via SMS.

This device will work as safety equipment especially for women. This circuit can be fitted in a purse. At the product level it can be as compact as a mobile phone. In the health care system, the temperature sensor can be replaced by heart beat monitor for heart patients or by calorie counter for diabetic patients. Along with the GSM Modem we could also add GPS Modem in order to detect the location. We also provide information about challenges faced in this field now and in near future.

I. ELECTRIC SHOCK CIRCUIT

The idea of implementing a small circuit which provides electric shock to the attacker is to get off the attacker and at the same time informing others about it. This circuit can be carried in a purse comfortably. We can provide electric shock to the attacker a no. of times. A Switch is provided in order to enable and disable the electric shock giving circuit. A Green colored LED is provided in order to indicate whether the circuit is in 'on' or 'off' state. As we can see below in Fig.1 the whole circuit diagram of the project,

As it can be seen from the figure, a 9V battery negative end is connected to one end of transformer and its positive end is connected to NO (Normally Open) of the HF3FA relay. When the switch is pressed, then a signal from microcontroller AT89SC51 is passed to several pairs of NPN transistors i.e. to ULN 2803 in order to amplify it. This electrical signal then taken to the common of relay. This shifts the pin from NC (Normally Close) to NO (Normally Open). This completes the circuit and the current flows through this to the transformer. The Secondary winding of transformer gives the electric shock. The transformer here used is step-up transformer. A constant 5V Supply voltage comes from 7805 i.e. a voltage regulator IC in order to keep the circuit in 'on' state. At the same time, a SMS is sent to the concerned people telling them about victim in danger using GSM Modem SIM 300.

II. HEALTHCARE SYSTEM

In our project, we are using temperature sensor LM 35 under the healthcare system in order to sense the body temperature. When LM 35 senses the temperature, it sends the analog data to ADC0804 i.e. Analog to Digital Converter. The ADC then sends its converted digital data in the form of 4-bit MSB and 4-bit LSB to the microcontroller. The microcontroller then sends the data serially to 16x2 LCD. When the temperature sensor senses the temperature above the normal body temperature then it sends the actual body temperature via SMS using GSM Modem SIM300 to the concerned people. The LCD displays the digital output.

III. EQUIPMENTS USED

A. AT89SC51

AT89S51 is a low-power, high-performance CMOS 8-bit microcontroller. It is highly-flexible and cost-effective. It has 8K bytes of flash Memory and 256 bytes of RAM. It consists of 32 I/O lines, watchdog timer, two data pointers, and three 16-bit timer/counters. It has six-vector two-level interrupt architecture. It also consists of a full duplex serial port, On-chip oscillator and a Clock circuitry. In our project, the microcontroller takes the data of LM 35 from ADC0804 and interfaces with the LCD in order to display the data.

B. LED

Gallium Phosphide (GaP) doped with N & Bi LED to indicate whether the circuit is 'on' or 'off'. We are using two different color LED'S. One is a red colored LED to indicate the supply voltage and another is green colored LED which indicates whether the electric shock circuit is 'on' or not. Forward voltage drop across red LED is nominally 1.6 V while the Green LED drops 2.4V. A Current limiting resistor of 1K ohms limits the forward diode current of the LED under test to a safe value.

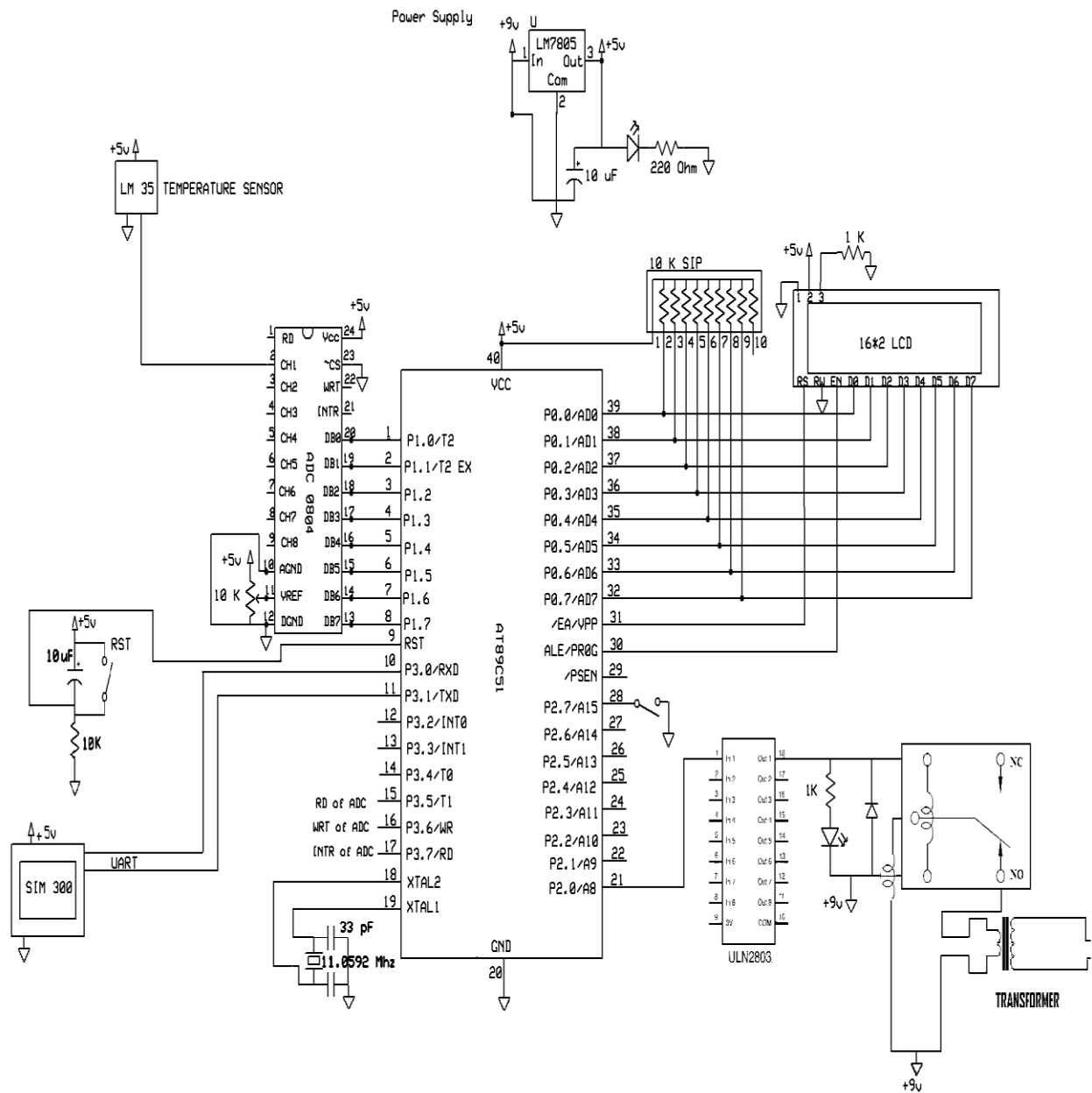

Fig.1. Circuit diagram of the gadget.

C. SIM 300

GSM/GPRS module SIM 300 is low power consumption device. It supports TCL band GSM/GPRS 900/1800/1900 MHz. The dimensions of the device are 33mm × 33mm × 3mm and weighs 7.8gm. It is controlled via AT commands. It has a SIM application toolkit. Supply voltage range supported is 3.4V to 4.5V. The SIM interface is powered from an internal regulator in the module having nominal voltage 2.8V. All pins reset as outputs driving low. You can use AT Command to get information in SIM 300. In our project, we will be using it to send SMS at critical time.

D. ADC 0804

ADC804 IC is an analog-to-digital converter. It works with +5 volts and has a resolution of 8 bits. In ADC804 conversion time varies depending on the clocking signals applied to CLK R and CLK IN pins, but it cannot be faster than 110 μs. CLK IN is an input pin connected to an external clock source. To use the internal clock generator (also called self-clocking), CLK IN and CLK R pins are connected to a capacitor and a resistor. The pin Vref/2 is used for the reference voltage. If this pin is open (not connected), the analog input voltage is in the range of 0 to 5 volts (the same as the Vcc pin). It also has D0-D7 the digital data output pins. These are tri-state buffered.

E. LM 35

The LM35 series are precision integrated-circuit temperature sensors, with an output voltage linearly proportional to the Centigrade temperature. The low output impedance, linear output, and precise inherent calibration of the LM35 make interfacing to readout control circuitry especially easy. The device is used with single power supplies, or with plus and minus supplies. As the LM35 draws only 60 μA from the supply, it has very low self-heating of less than 0.1°C in still air.

The LM35 is rated to operate over a -55°C to +150°C temperature range, while the LM35C is rated for a -40°C to +110°C range (-10° with improved accuracy).

F. ULN 2803

ULN2803 is high-voltage; high-current drivers comprised of eight NPN transistors pairs. The maximum output current (single output) is 500mA and high sustaining voltage output is 50V. The inputs are compatible with various types of logic.

G. IN 4007

In our project, IN 4007 diode limits the feedback current.

It has high maximum operating temperature, low leakage current and excellent stability.

H. HF3FA

It is a Subminiature High power Relay with 15 A switching capability and 2.5 kV dielectric strength. It has 5 pins.

I. TRANSFORMER

In our project, we are using a step-up transformer of voltage ratio 5:1. Here, we are providing DC supply to the transformer for some microseconds. When the DC current is disconnected, this stored energy wants to leave the core of the transformer. It can do this by inducing a voltage in either of the windings. If both windings are open circuit, this voltage can be very high.

IV. ADVANTAGES

Below is the list of advantages of the gadget:-

- Compact in size.

- Easy to use.
- Easy Maintenance.
- Blood Pressure Sensors, Heart beat Monitor or Calorie meter can be used instead of temperature system.
- It acts as a Safety Device which can be carried by everyone.

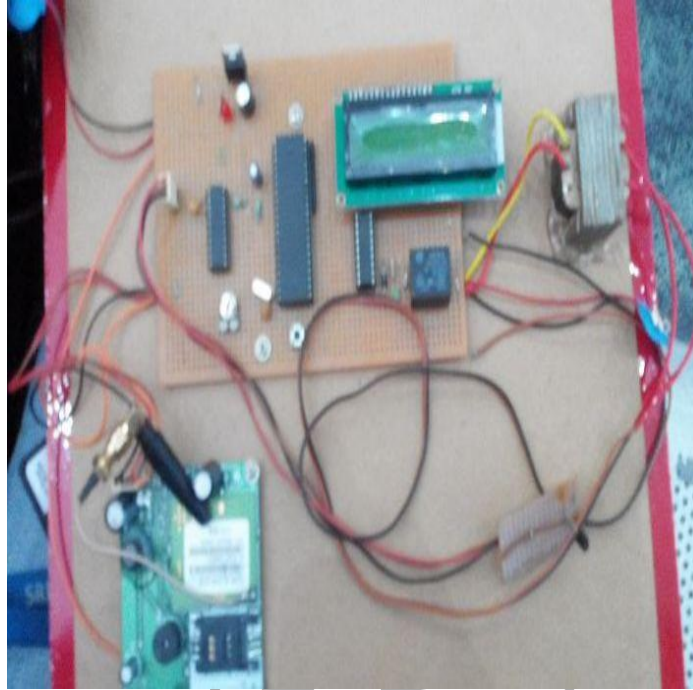

Fig.2. Eve Teasing Avoidance Gadget Model.

V. DISADVANTAGES

Below is the list of disadvantages of the gadget:-

- There is a possibility of the misuse of the gadget.
- It requires +9v constant supply.

VI. CONCLUSION

Being safe and secure is the demand of the day. Our endeavor behind this project is to design and fabricate a gadget which is so compact in itself that provide advantage of Security plus provide a health check system. In near future, this will be a boon to the world. This device will probably be very useful for the women. It is certainly a short term and preventive solution. This will be proved as a multipronged strategy with the participation of multi stake holders of society.

REFERENCES

1. Elia Nadira Sabudin, Siti Zarina Mohd Muji, Mohd. Helmy Abd Wahab, Ayob Johari, Norazman Bin Ghani, "GSM-based Notification Speed Detection for Monitoring Purposes", IEEE, Department of Computer Engineering, University Tun Hussein in Malaysia in 2008.
2. M. AL-Rousan, A. R. AI-Ali and K. Darwish "GSM-Based Mobile Tele-Monitoring and Management System for Inter-Cities Public Transportations", International Conference on Industrial Technology (ICIT), Computer Engineering Dept., American University of Sharjah, UAE in 2004, pages859-862.

3. Stephen Teang Soo Thong, Chua Tien Han and Tharek Abdul Rahman “Intelligent Fleet Management System with Concurrent GPS & GSM Real-Time Positioning Technology”, IEEE ,Wireless Communication Centre(WCC), university Teknologi Malaysia (UTM), Malaysia in 2007.
4. Hui Hu, Lian Fang “Design and Implementation of Vehicle Monitoring System Based on GPS/GSM/GIS” Third International Symposium on Intelligent Information Technology Application ,School of Information Engineering, East China Jiao Tong University, Nanchang, Jiangxi, China in 2009. Pages 278-279.
5. Thuong Le-Tien, Vu Phung-The “Routing and Tracking System for Mobile Vehicles in Large Area”, Fifth IEEE International Symposium on Electronic Design, Test & Applications Dept. of Electrical Electronics Engineering, HCM University of Technology, Vietnam in 2010.
6. Umar Farooq, Tanveer ul Haq, Muhammad Amar, Muhammad Usman Asad, Asim Iqbal “GPS-GSM Integration for Enhancing Public Transportation Management Services” Second International Conference on Computer Engineering and Applications, Department of Electrical Engineering University of The Punjab Lahore-54590, in 2010.
7. T.Shyam Ramanath, A.Sudharsan, U.Pelix Udhayaraj, “Drunken Driving and Rash Driving Prevention System”, International Conference on Mechanical and Electrical Technology (ICMET 2010), Sri Sai Ram Engineering College, Chennai, India in 2010, page 603.
8. Muruganandham, P.R.Mukesh “Real Time Web based Vehicle Tracking using GPS”, World Academy of Science, Engineering and Technology in 2010.
9. Datasheet and specifications of 89C51 microcontroller. [Online]. Available:[http://www.atmel.com/PFResults.aspx#\(data:\(category:'34864',type:!\(16\)\),sc:3\)](http://www.atmel.com/PFResults.aspx#(data:(category:'34864',type:!(16)),sc:3)).
10. Datasheet of GSM/GPRS module SIM 300. [Online]. Available:<http://www.alldatasheet.com/view.jsp?Searchword=SIM300>.
11. ST Electronics Co., Ltd., Data Sheet for LM358, January 2012,<http://www.st.com/internet/analog/product/63721.jsp>