

Developing Islanding Arrangement Automatically For Grid on Sensing Voltage or Frequency Beyond Range

Mr.Nitin Dhama

Assistant Professor
Department of ECE
SRM University NCR Campus
Modinagar

Abhishek Gupta, Ajay Mundra, Ekta Rai, Shreya Singh

B.Tech Student
Department of ECE
SRM University NCR Campus
Modinagar

ABSTRACT-

This paper focuses on some fundamental challenges facing the utilization of electricity today and for years to come. In power distribution systems, the power grid station gets supply from different feeder stations like a thermal power station, a wind power station, a solar power station etc. For feasible transmission, the frequency and voltage of the AC supply should be within the limits as decided by the grid, depending upon the demand of the power supply. In case these limits are exceeded and the demand for power is more than the demand for supply, it results in grid failure. In such situations, the feeder unit is completely disconnected from the grid, causing islanding situation. Thus synchronization is needed between the grid and the feeder unit.

This paper defines a way to determine any synchronization failure. Here a frequency and a voltage variation detection system are used. The frequency variation is achieved using an external timer and detection is achieved using the internal timer of the microcontroller. The voltage variation is achieved using a Voltage Regulator and detection is achieved using a comparator arrangement and any variation in voltage is detected by the microcontroller. In case of any voltage or frequency variations, the lamp is switched off.

I. INTRODUCTION

This paper provides an idea that seems rather imminent today and supplements them with a few visionary thoughts. Several new trends are already shaping changes in the electricity infrastructure including the expansion of the existing grid with micro grids and mega grids, extensive sensors, data processing, visualization tools, etc. This leads to idea of Automatic Grid synchronization concept. Increasing electrical energy demand, modern lifestyles and energy usage patterns have made the world fully dependant on power systems thus the need of a reliable and stable power system grid. However, the power system is a highly nonlinear system, which changes its operations continuously. Therefore, it is very challenging and uneconomical to make the system be stable for all disturbances. The system is usually designed to handle a single outage at a time. However, during the last decade several major blackouts were reported and all of them started with single outages. This paper mainly based on techniques to minimize blackouts.

II. ISLANDING

Islanding refers to the condition in which a distributed generator (DG) continues to power a location even though electrical grid power from the electric utility is no longer present. Islanding can be dangerous to utility workers, who may not realize that a circuit is still powered, and it may prevent automatic re-connection of devices. For that

reason, distributed generators must detect islanding and immediately stop producing power; this is referred to as anti-islanding.

The common example of islanding is a grid supply line that has solar panels attached to it. In the case of a blackout, the solar panels will continue to deliver power as long as irradiance is sufficient. In this case, the supply line becomes an "island" with power surrounded by a "sea" of unpowered lines. For this reason, solar inverters that are designed to supply power to the grid are generally required to have some sort of automatic anti-islanding circuitry in them. Electrical inverters are devices that convert direct current (DC) to alternating current (AC). Grid-interactive inverters have the additional requirement that they produce AC power that matches the existing power presented on the grid.

Consider the case of a house with an array of solar panels on the roof. Inverter(s) attached to the panels convert the varying DC current provided by the panels into AC power that matches the grid supply. If the grid is disconnected, the voltage on the grid line might be expected to drop to zero, a clear indication of a service interruption. However, consider the case when the house's load exactly matches the output of the panels at the instant of the grid interruption. In this case the panels can continue supplying power, which is used up by the house's load. In this case there is no obvious indication that an interruption has occurred.

Normally, even when the load and production are exactly matched, the so-called "balanced condition", the failure of the grid will result in several additional transient signals being generated. For instance, there will almost always be a brief decrease in line voltage, which will signal a potential fault condition. However, such events can also be caused by normal operation, like the starting of a large electric motor.

One of the methods that detect islanding without a large number of false positives is discussed later in circuit explanation part of this paper.

CAN BLACKOUTS BE MADE LESS LIKELY?

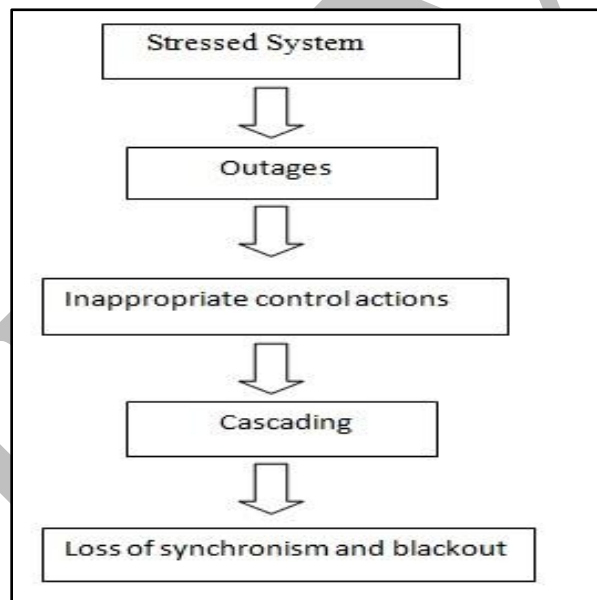

CIRCUIT EXPLANATION:

The DC power supply part consists of the AC supply being stepped down using a step down transformer. A bridge rectifier consisting of diodes converts this AC to pulsating DC voltage, which is regulated using a regulator IC. This DC supply is then given to the Microcontroller and the other parts of the circuit.

FREQUENCY SENSING PART:

The Voltage Regulator is adjusted such that the AC input voltage is at its normal value. The microcontroller pin is connected to the output of the timer through a PNP transistor. The timer works in a stable mode to produce signals at frequencies which can be adjusted using the variable frequency. This output is connected to the internal timer of the microcontroller which accordingly calculates the frequency of the frequency, the relay driver is triggered, which in turn energizes the relay and the AC supply is given to the lamp which turns off once the frequency of the pulses goes beyond the normal frequency or less than the normal.

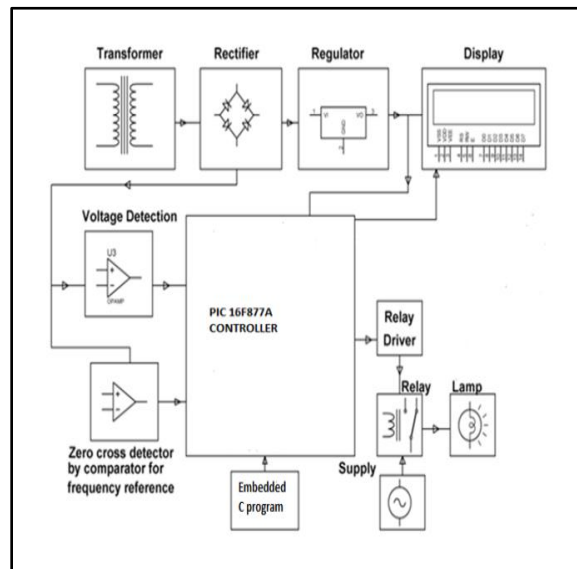
BLOCK DIAGRAM**VOLTAGE SENSING PART:**

The microcontroller is connected to the zero voltage sensing circuit to ensure the frequency of the supply is at normal frequency of 50Hz. A Voltage Regulator is used to get variable voltage.

Initially both the presets are adjusted such that both the output pins of the OPAMP IC are at normal low and normal high level. At this point the lamp is glowing as the voltage is in the range. The Voltage Regulator is adjusted so as to get the input AC voltage more than the normal value. Now the normally high pin of the OPAMP IC will go low, giving an interruption pulse to the pin of the microcontroller. The microcontroller accordingly sends a high logic pulse to switch off the relay driver, which in turn de-energizes the relay driver making the lamp to turn off. Similarly when the Variable Regulator is adjusted so as to get input AC voltage less than the normal value, at some point, the normally low pin of the OPAMP IC goes high and the microcontroller on receiving this interruption, sends a high logic signal to the relay driver to switch off the relay and hence the lamp which stops glowing.

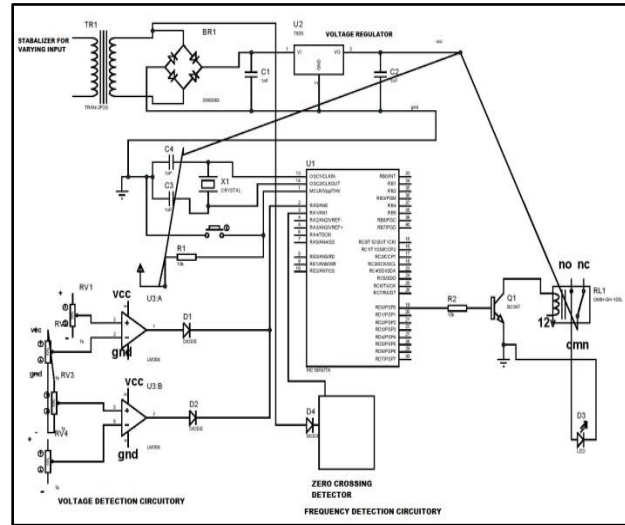
CIRCUIT DIAGRAM**IV. CONCLUSION**

As discussed in this paper, several future grid developments are expected: • increased use of renewable variable generation at both the bulk and distributed level; • profound involvement of customers in all aspects of electricity generation and uses; • increased penetration of automation at both the distribution and transmission level; • more comprehensive planning strategies that will deploy risk-based techniques to cope with uncertainty. Several issues have been recognized but not explored in this paper due to lack of space and the need to have specialized expert focus:

- Cyber security and physical security will play a never increasing role in all future grid developments.
- Advancements in the materials ranging from superconductive compounds to new nanoscale structures will be a continued quest in the future. This will result in provision of societies energy needs in a way that is sustainable for the 21st century and beyond.

V. REFERENCES

1. J. McCalley, W. Jewell, T. Mount, D. Osborn, and J. Fleeman, BA wider horizon: Technologies, tools, and procedures for energy systems planning at the national level,[IEEE Power Energy Mag., vol. 9, no. 3, pp. 42–54, May/June. 2011].
2. J. Duncan Glover, Mulukutla S. Sarma, and Thomas J. Over byes Power System Analysis and design, fourth edition chapter 1,2.
3. J. B Gupta's 10th edition power system part 2 transmission and distribution of electrical power pg 367.
4. S.N. Singh ,S.C. Srivastva, Electric power industry reconstructing in India, Present Scenario and future prospects, Senior Members, IEEE.
5. J.D McDonald, "Substation Automation IED integration and Availability of information". IEEE Power Energy Mag. vol. 1,no. 2,PP.22-31,Mar./Apr. 2003.
6. B.Roberts, "Capturing Grid Power," IEEE Power Energy Mag., vol.7, no.4, pp.32-41, Jul./Aug.2009.